

Rack Mount Industrial Display Monitor

Model # RM-3x56

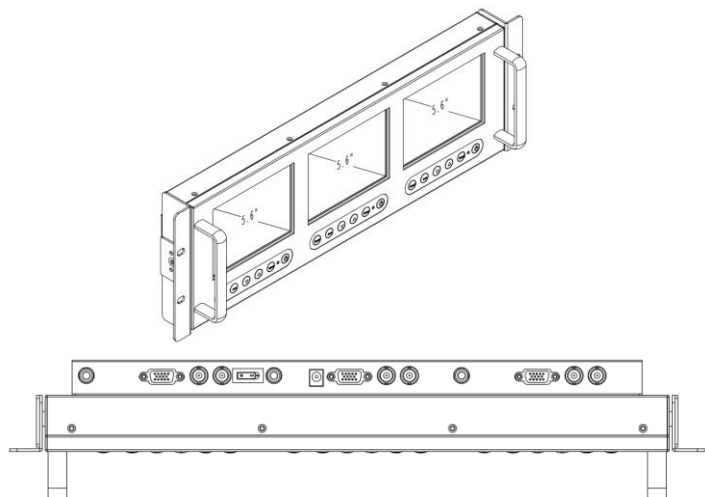

Features

- Compact 19 inch rack mountable with 3.5U height
- Triple 5.6 inch LCD panel, support 640 x 480 resolution
- VGA, Composite Video Input
- 90 ° tilt adjustment while mounted in rack: 45° ~-45° (V)
- Heavy duty steel chassis with hardness glass protect screen
- Front osd control buttons to optimized display

Option

- DC 9~36 V power input
- AR Hardness glass
- Touch screen

LCD Characteristics :

Screen Size	5.6 inch
Backlight Type	LED
Resolution	640x480
Contrast Ratio	500:1
Brightness (cd/m2)	200
View Angles (H/V)	140/120
Pixel Size (HxV) mm	0.0588x0.1764
Max. Color	262K
MTBF (Hrs.)	50,000

Input Signals:

VGA	D-SUB 15Pin Connector (Female)
Composite Video	RCA plug
Audio	3.5" Jack
Power Input	External power adapter
Touch-USB (option)	USB A Type connector
Touch-RS232 (option)	D-SUB 9P connector (Female)

Power Specifications :

AC Power Input	100-240VAC / DC 12V external AC adapter
Wide Range DC Power Input (option)	Screw Type Terminal Block with internal wide Range DC 9-36V power module

User Controls Interface:

Power ON / OFF via Front Button
Power Mode Status LED indicator
OSD (On Screen Display) Buttons

Mechanical and Environment:

Height	3.5U
IP Protect	N/A
Mounting	Rack Mount
Construction	Metal Housing
Operating Temperature	0 - 50 deg. C
Operating Humidity	5% - 95% (non -condensing)
Anti-Vibration	5 - 500 Hz / 1 Grms PTP
Anti-Shock	15G / Peak (11 ms)
Physical Dimension (WxHxD)	482 x 152 x 63 (mm)
Packing Dimension (WxHxD)	600 x 190 x 290 (mm)
Net Weight / Gross Weight	(KGs)
Certification and Approvals	CE / FCC / RoHs

