

- NOTE:
1. ALL BURS MUST BE FILLED TO (0.05) mm
 2. FINISH: COATING (SPEC. SEE SAMPLE)
 3. TOLERANCE UNLESS OTHERWISE SPEC. SEE TOLERANCE TABLE

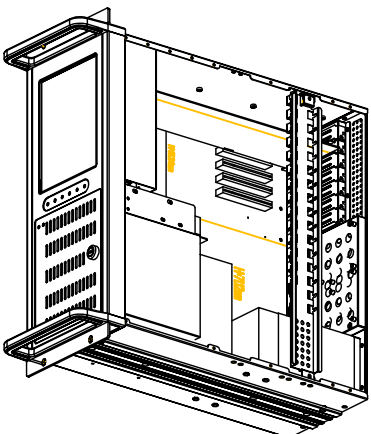

TDL	30 120 315	±0.1 ±0.15 ±0.2 ±0.3	UNIT : mm	FINISHING	MOLD Name	Ver.	A0
ANGLE TOL	< 30 < 120 < 315	±0.5°	3RD ANGLES	MATERIAL	MOLD NO.	Qty	1
				APPROVED	PART NO.		
				CHECKED	TITLE		
				DESIGNED	DRAWING NO.		
				DRAWN	SIZE	A4	



MARK	DESCRIPTION	SING	DATE
△			
△			
△			

SCALE	1/1
SHEET	1 OF 1
DATE	2023/08/01
DESIGNED	SJL
DRAWN	SJL
CHECKED	
APPROVED	
DESIGNED	SJL
DRAWN	SJL
CHECKED	
APPROVED	
DESIGNED	SJL
DRAWN	SJL
CHECKED	
APPROVED	